

TWT-27D-2-HC

 Worktop Counter Refrigerator, 2 Drawers

Dimensions		Build		Technical	
External Width (mm)	702	Number of Drawers	2	Temperature Holding	0.5 : 3.3°C
External Depth (mm)	766	Exterior Construction	Stainless steel front & countertop, aluminium sides & rear	Refrigerant	R290
External Height (mm)	1004	Interior Construction	Clear coated aluminium, stainless steel base	Voltage / Frequency / Phase	220-240V/50-60Hz/1
Exclusions	Depth does not include 26 mm for rear bumpers.	Air Intake Position	Front	Amps	0.8
Net Volume (Litres)	39	Ventilation Position	Front	Wattage	184
Gross Volume (Litres)	184	Clearance Required	Zero back and sides	Climate Class	5
Per Drawer Capacity (max depth mm)	1x 1/1 GN (150)	Cord Length (Meters)	2.13	Operating Statement	Heavy Duty: This appliance is intended for use in ambient temperatures up to 40°C.
Unpackaged Weight (kg)	87	Standard w/ Locks	Standard	Testing Standard	EN 16825
Packaged Weight (kg)	98			EEC	A
Packaged Dimensions (W x D x H mm)	769 x 839 x 1207			EEL	23.9
Supplied Supports	ø 127 mm castors (158 mm height)			kWh/24hr	1.24
				kWh/Annum	451
				Defrost Type	Auto

TWT-27D-2-HC

Worktop Counter Refrigerator, 2 Drawers

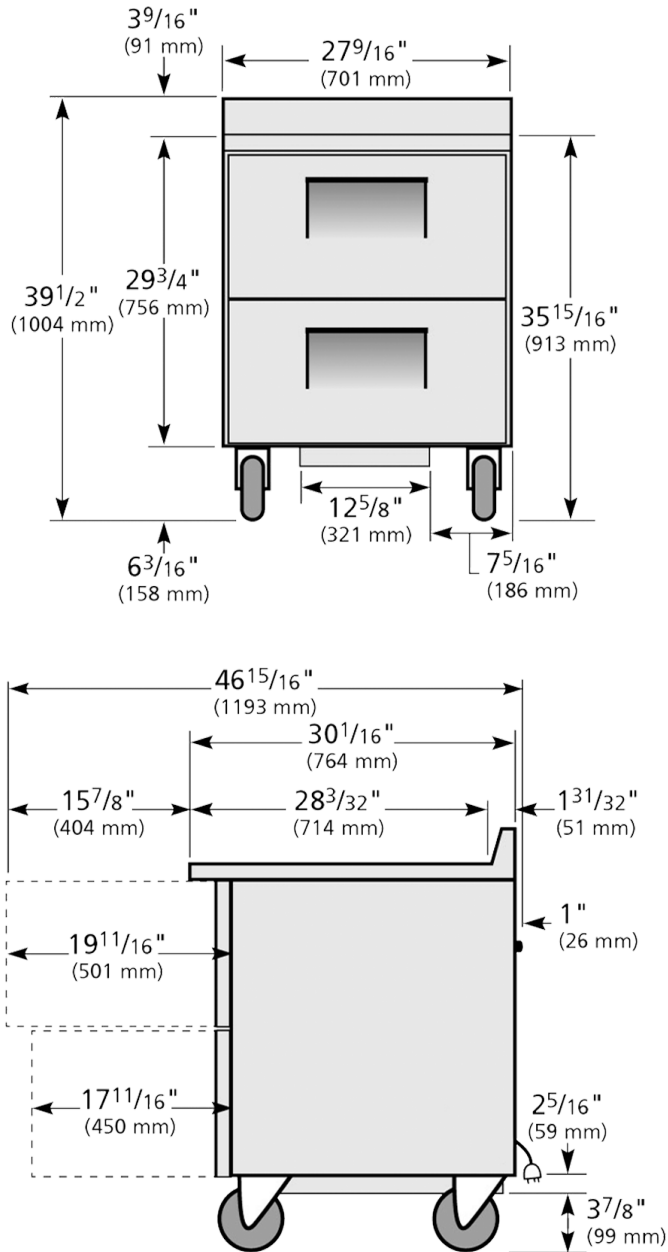

WARRANTY 5 YEARS
PARTS, COMPRESSOR AND LABOUR
natural refrigerant.

Specifications subject to change without notice.
Technical data above related to energy use based on testing of 50Hz or Dual Frequency models
Chart dimensions rounded up to the next whole millimeter (inches rounded up to the 1/8")

WA DEALER
PRACTICAL PRODUCTS PTY LTD

PH: 08 9302 1299
51 Paramount Dr Wangara WA 6065
sales@practicalproducts.com.au
www.practicalproducts.com.au

